

# CD103M Dri-Prime® Pumps

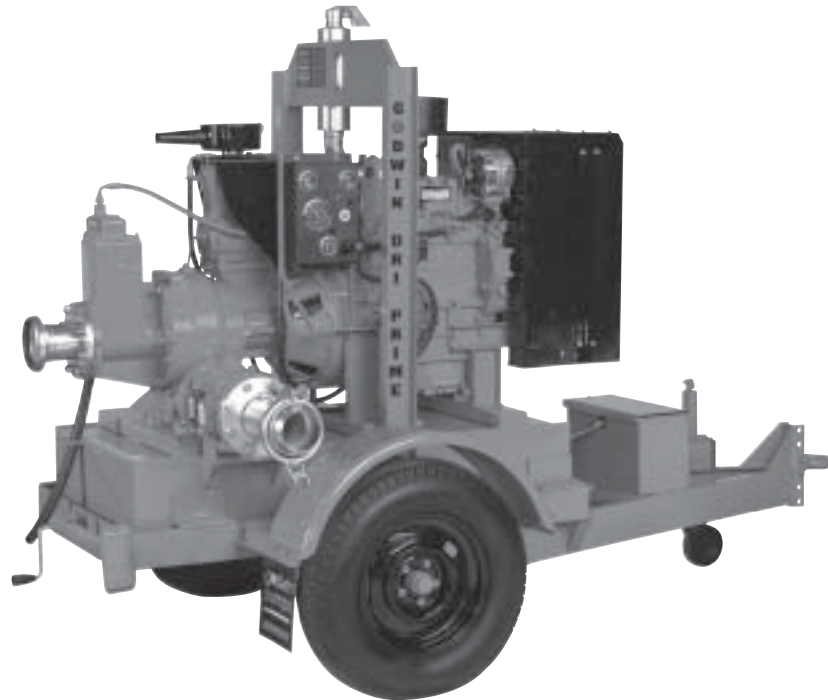

The Godwin Dri-Prime 4 inch (100mm) CD103M automatic priming centrifugal pump is a highly maneuverable portable trash pump with flow capabilities to 1,000 gallons per minute (833 Imperial GPM), total dynamic heads to 170 feet (52 meters) and solids handling to 3 inch (75mm) in diameter. The unique Godwin venturi air evacuation system allows the CD103M to prime from dry conditions with suction lifts up to 28 feet (8.5 meters). Perfect in intermittent flow situations, the CD103M can run dry indefinitely without damage due to the oil bath mechanical seal design. For sewage handling, dewatering, municipal usage, and many other applications, the Godwin CD103M with 4 inch (100mm) hoses is a powerful, yet versatile and portable pumping system.

## Features

- Close coupled centrifugal pump with vacuum priming compressor mounted to a diesel engine. Also available in electric drive or as bare shaft pumpend.
- All cast iron construction with cast chromium steel impeller.
- Extensive application flexibility — will handle raw sewage, slurries and liquids with solids up to 3 inch (75mm) in diameter.
- Continuously operated “Godwin” air ejector priming device requiring no form of periodic adjustment or control.
- Dry running, high pressure oil bath mechanical seal with abrasion resistant solid Silicon Carbide interfaces.
- Compact unit mounted on skid base or two wheeled highway trailer both incorporating integral overnight running fuel tank.
- Simple maintenance — normally limited to checking engine and seal cavity oil levels.
- Standard engine — John Deere 4024T. Available with a variety of engines including Caterpillar, Hatz, Perkins and Deutz.
- A variety of silenced sets are available.

# CD103M Performance Curve

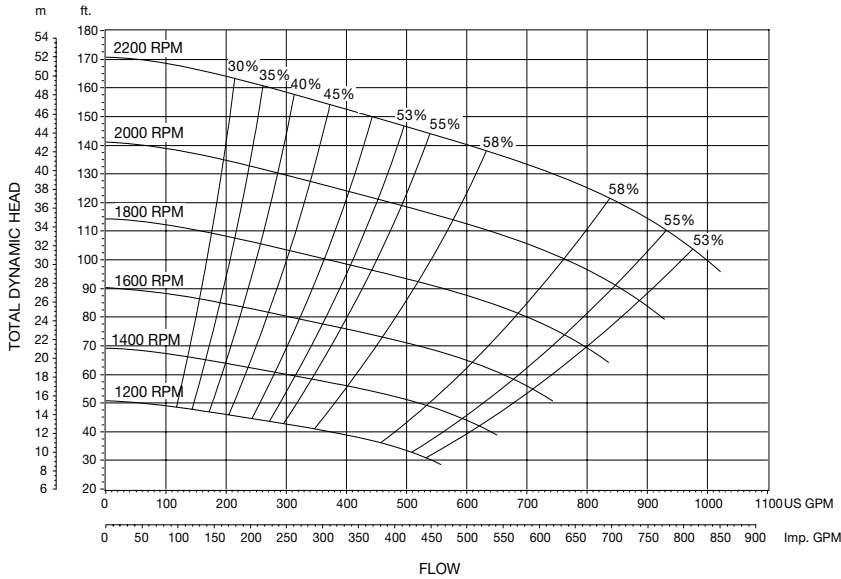

## CD103M Performance Table

**Diesel Set** — John Deere 4024T, 41 hp @ 2200 rpm  
**Impeller Diameter** — 10-7/16 in. (256 mm)

Total Suction Head - Feet	Total Delivery Head — Feet				
	60	80	100	120	140
10	1030	1015	920	740	440
15	1010	960	880	680	360
20	890	860	785	600	270
25	800	760	720	520	180

Performance data listed in table and curves are based on water tests at sea level and 68° F (20° C). Larger diameter pipes may be required for maximum flows.

## Dimensions

**CD103M** — John Deere 4024T, GP60 Highway Trailer  
 Weight: 4,000 lbs. (1,818 kg.)

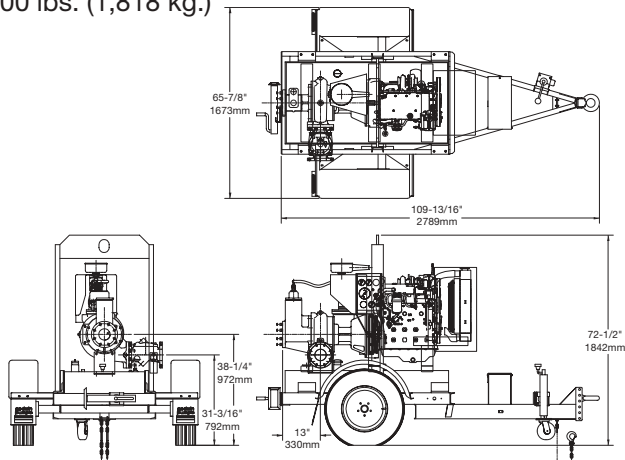

## Specifications

- Maximum Operating Speed:** 2200 rpm
- Maximum Operating Temperature:** +176° F (80° C)
- Maximum Working Pressure:** 64 psi (4.4 BAR)
- Maximum Suction Pressure:** 73 psi (5.0 BAR)
- Maximum Casing Pressure:** 97 psi (6.7 BAR)
- Fuel Tank Capacity:** 60 gallons (227 liters)
- Fuel Consumption** (full load, max. speed): 2.3 gph (8.7 lph) @ 2200 rpm
- Pipe Connections:** 4" (100mm) ASA 150#
- Solids Handling:** 3" (75mm) dia. standard impeller

## Materials

- Pump Casing, Suction Cover, Separation Tank and Wearplates:** Close grained cast iron
- Impeller:** Cast chromium steel – Minimum Brinell 220 HB
- Shaft Sleeve and Shaft:** 1-1/2% nickel/chromium steel
- Non Return Valve Body:** Close grained cast iron
- Non Return Valve Ball and Seat:** High nitrile rubber
- Mechanical Seal Faces:** Solid Silicon Carbide



One Floodgate Road, Bridgeport, NJ 08014, USA  
 (856) 467-3636 • Fax: (856) 467-4841  
 Quenington, Cirencester, Glos., GL7 5BX, UK  
 +44 (0)1285 750271 • Fax: +44 (0)1285 750352

E-mail: sales@godwinpumps.com  
 www.godwinpumps.com

**BRANCH LOCATIONS:**  
 Connecticut • Pennsylvania • New York • Ohio  
 Illinois • Maryland • Virginia • West Virginia  
 Georgia • South Carolina • North Carolina  
 Florida • Texas • Montana • California • Washington

Dri-Prime® and the color orange for pumps are registered trademarks of Godwin Pumps of America, Inc. Specifications and illustrations are subject to revision without notice. © Copyright 2004 Godwin Pumps of America, Inc.