

CD250M Dri-Prime® Pumps

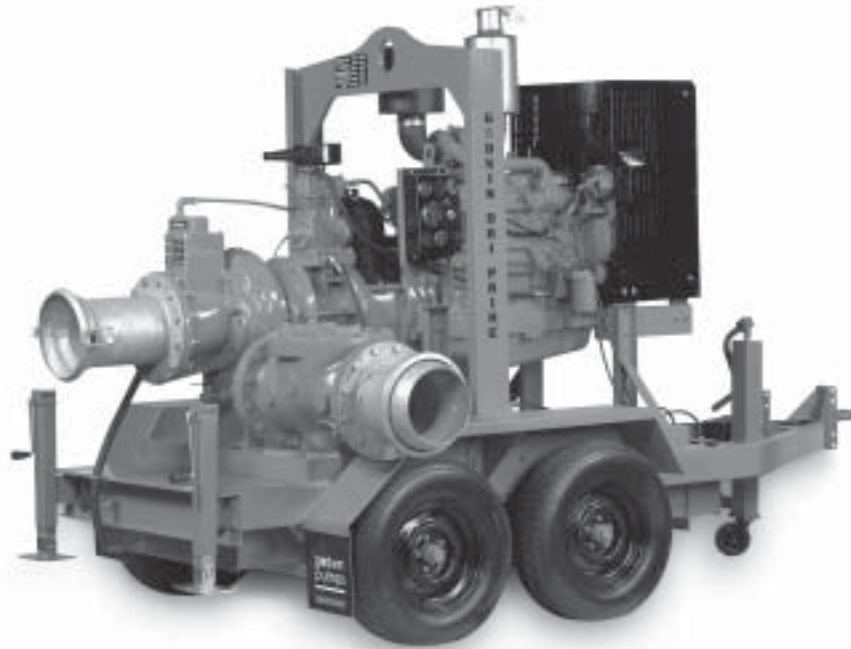

An extremely rugged pump, the 10" (250mm) CD250M Dri-Prime pump is capable of flow rates to 3600 gpm (227 l/sec.), total dynamic heads to 180' (54.9 meters), and solids handling capabilities up to 3-1/8" (79mm) in diameter. The CD250M also features the unique Godwin high pressure oil bath mechanical seal that allows for indefinite dry running, perfect for intermittent flow applications. All of these features come standard on a highly maneuverable highway trailer or compact skid for convenient use.

Features

- Close mounted arrangement carrying pump and vacuum priming compressor mounted to a diesel engine or electric motor.
- Cast iron construction solids handling pumpend. Stainless steel and other hardened materials also available.
- Extensive application flexibility — will handle raw sewage, slurries and liquids with solids up to 3-1/8" (79mm) in diameter.
- Continuously operated "Godwin" air ejector priming device requiring no form of periodic adjustment or control.
- Dry running, high pressure oil bath, mechanical seal with high abrasion resistant silicon carbide interfaces.
- Solids handling swing check Non Return Valve.
- Compact unit mounted on a skid base or two-wheeled highway trailer both incorporating integral overnight running fuel tank.
- Simple maintenance, normally limited to checking engine and seal cavity oil levels.
- Standard John Deere 6068T or Caterpillar 3056TA engine. Also available with a variety of other diesel engines or electric drive motor.
- A variety of silenced units are available.
- Balanced unit with centralized lifting bracket for easy handling.

CD250M Performance Curve

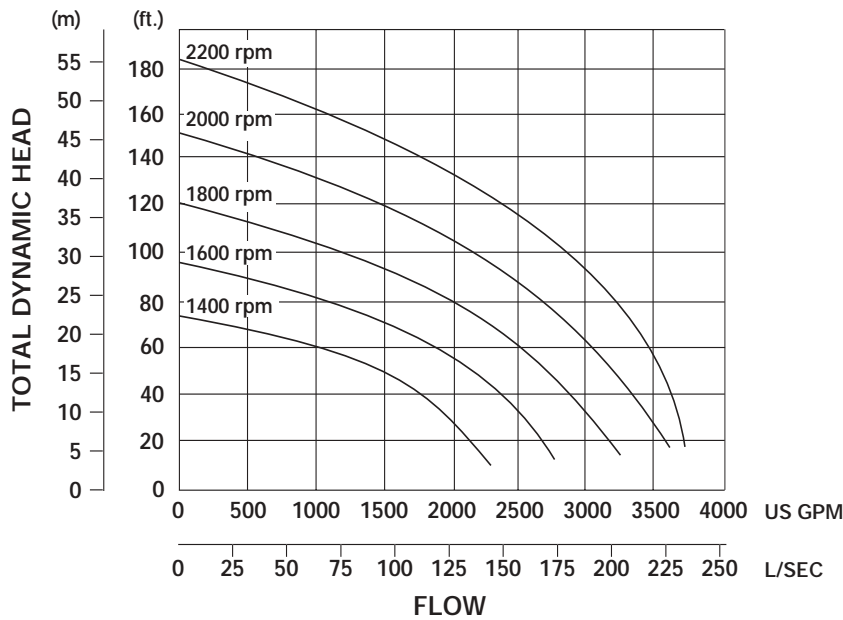

Performance Table

Diesel Set — John Deere 6068T, 147 hp (109.6 kw) @ 2200 rpm
 Caterpillar 3056TA, 155 hp (115.6 kw) @ 2200 rpm
Impeller Diameter — 11-3/8 inches (290 mm)

Total Delivery Head — Feet

Total Suction Head — Feet	Output — GPM			
	40	60	80	100
15	3400	3200	2900	2500
20	2700	2600	2350	2160
25	2510	2320	2150	1810

Performance data listed in table and curves based on water tests at sea level and 68° F (20° C). Larger diameter pipes may be required for maximum flows.

Dimensions

CD250M — John Deere 6068T Engine, GP7052 Trailer
 Weight: 7,000 lbs. (3,181.8 kg.)

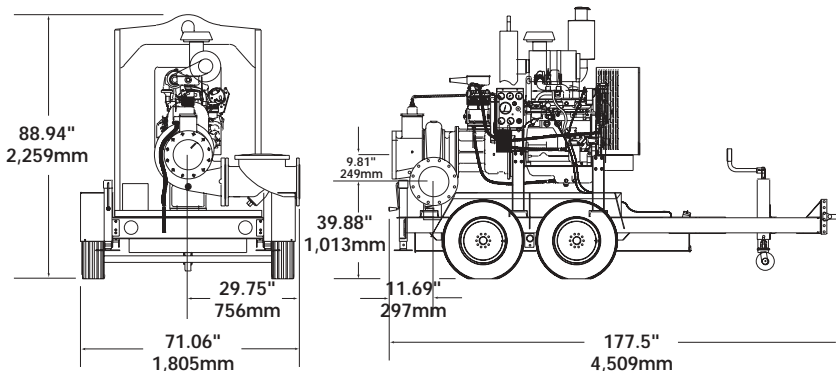

Specifications

- Maximum Operating Speed:** 2200 rpm
- Maximum Operating Temperature:** +212° F (100° C)
- Maximum Working Pressure:** 78.0 psi (5.4 BAR)
- Maximum Suction Pressure:** 100 psi (6.9 BAR)
- Maximum Casing Pressure:** 117 psi (8.1 BAR)
- Fuel Tank Capacity:** 150 gallons (568 liters)
- Fuel Consumption:** JD 6068T: 7.4 gph (28 lph) @ 2200 rpm
Cat 3056TA: 7.0 gph (30 lph) @ 2200 rpm
- Pipe Connections:** 10" (250mm) ASA 150#
- Solids Handling:** 3-1/8" (79mm) diameter

Materials

- Pump Casing, Suction Cover, Separation Tank and Wearplates:** Close Grained Cast Iron
- Impeller:** Cast Chromium Steel hardened to minimum Brinell 341 HB
- Shaft:** 1-1/2% Nickel/Chromium Steel
- Non Return Valve Body & Ejector Housing:** Close Grained Cast Iron
- Non Return Valve Flapper:** High Nitrile Rubber
- Mechanical Seal Faces:** Solid Silicon Carbide



One Floodgate Road, Bridgeport, NJ 08014, USA
 (856) 467-3636 • Fax: (856) 467-4841
 Quenington, Cirencester, Glos., GL7 5BX, UK
 +44 (0)1285 750271 • Fax: +44 (0)1285 750352
 E-mail: sales@godwinpumps.com
 www.godwinpumps.com

BRANCH LOCATIONS:

Norwich, CT • Buffalo, NY • Chicago, IL • Pittsburgh, PA
 Washington, DC • Richmond, VA • Virginia Beach, VA
 Charleston, WV • Raleigh, NC • Charlotte, NC
 N. Charleston, SC • Atlanta, GA • Houston, TX
 San Antonio, TX • Helena, MT • Los Angeles, CA

Dri-Prime® and the color orange for pumps are registered trademarks of Godwin Pumps of America, Inc. Specifications and illustrations are subject to revision without notice.
 © Copyright 2003 Godwin Pumps of America, Inc.