

GSL30, GSL35 Sub-Prime® Electric Submersible Sludge Pumps

The line of Godwin Sub-Prime GSL electric submersible pumps is designed for large sludge or dewatering applications. The GSL30 and GSL35 models are capable of maximum flow rates from 205 to 220 gpm (12.9 to 13.9 l/sec) and discharge heads to 59 feet (18M). Like the dewatering models in the Sub-Prime line, these submersible sludge pumps are suited to tough construction, mining and industrial applications. The design features a side discharge that handles solids up to 2" (50mm) in diameter and rugged construction for long life, including a cast chromium steel impeller and heavy duty polyurethane-lined volute. Other benefits include tandem mechanical seals for dry running and extra protection against leakage, and a dual voltage junction chamber (GSL35) for convenient changeover in the field.



Features

- Side discharge design handles solids up to 2" (50mm) in diameter
- Oversized power cable
- Dual voltage junction chamber (GSL35)
- High performance submersible motor
- Oversized, heavy duty ball bearings
- Tandem mechanical seals – Silicon Carbide on Silicon Carbide primary seal
- Cast Chromium Steel vortex impeller and heavy duty polyurethane-lined volute
- Lightweight aluminum and corrosion resistant stainless steel construction
- Dry running capabilities
- Optional manual and automatic control panels available

Specifications

	Model	
	GSL30 Single Phase	GSL35 Three Phase
<i>HP (kW)</i>	3.0 (2.2)	3.5 (2.6)
<i>Max. GPM (l/sec.)</i>	205 (12.9)	220 (13.9)
<i>Max. Head - Ft. (M)</i>	57' (17.4M)	59' (18.0M)
<i>Discharge</i>	3" (75mm)	3" (75mm)
<i>Cable</i>	65' (20M)	65' (20M)
<i>RPM</i>	3400	3400
<i>Max. Temp.</i>	103°F (40°C)	103°F (40°C)
<i>PH Range</i>	5.0-8.0	5.0-8.0
<i>Voltage</i>	230	230/460
<i>Phase</i>	1	3
<i>Amps</i>	16	10.0/5.0
<i>Weight</i>	62 lbs. 28 kg.	62 lbs. 28 kg.
<i>Max. Solids</i>	2" (50mm)	2" (50mm)

godwin
pumps



GSL30, GSL35 Sub-Prime® Performance Curves

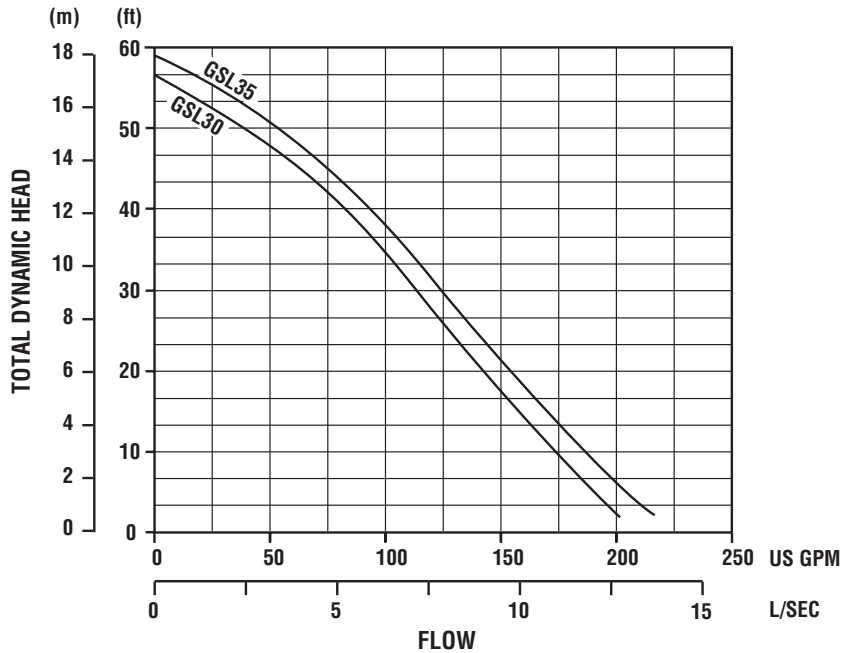

WARNING: Pumps are not designed for use in explosive atmosphere, flammable environments or for pumping volatile liquids.

Design & Construction

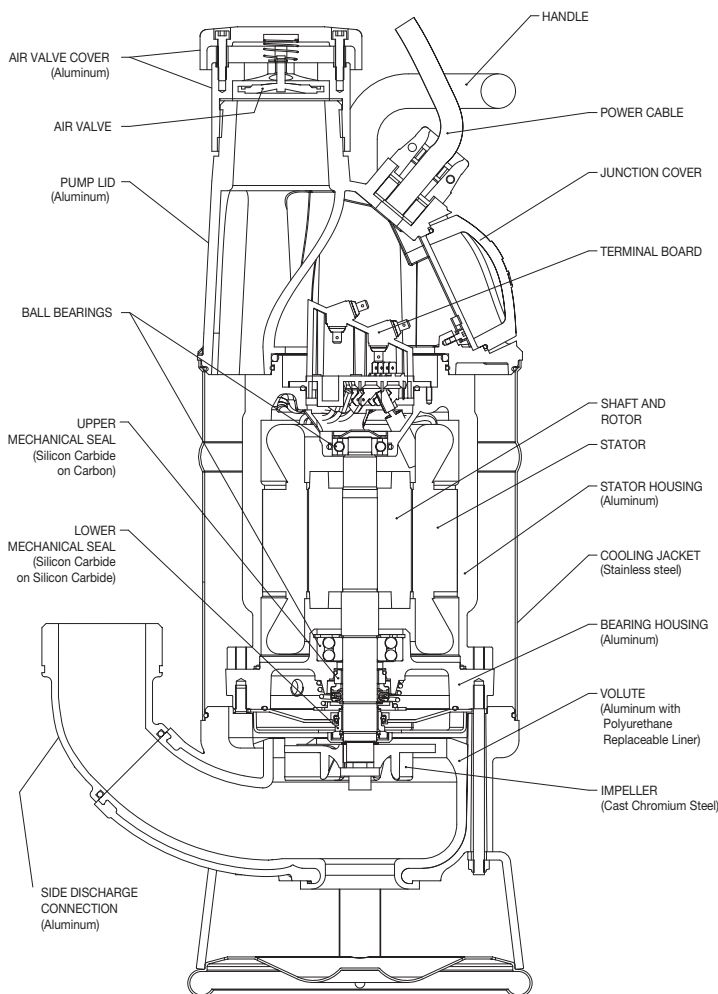

Dimensions

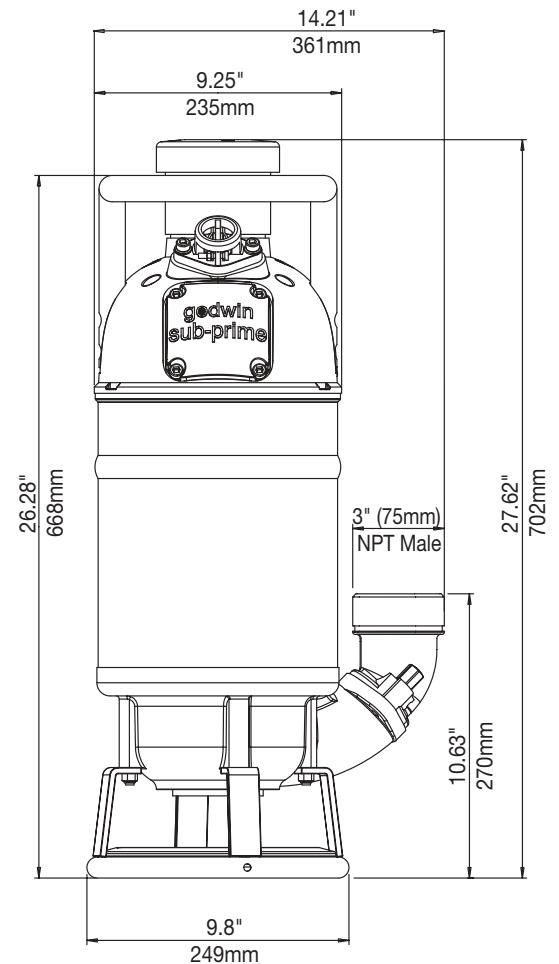

godwin
pumps



One Floodgate Road, Bridgeport, NJ 08014, USA
(856) 467-3636 • Fax: (856) 467-4841

Quenington, Cirencester, Glos., GL7 5BX, UK
+44 (0)1285-750271 • Fax: +44 (0)1285-750352

E-mail: sales@godwinpumps.com

www.godwinpumps.com

BRANCH LOCATIONS:

Connecticut • Pennsylvania • New York • Ohio
Illinois • Maryland • Virginia • West Virginia
North Carolina • South Carolina • Georgia
Florida • Texas • Montana • California • Washington

Sub-Prime® and the color orange for pumps are registered trademarks of Godwin Pumps of America, Inc. Specifications and illustrations are subject to revision without notice.
© Copyright 2003-2005 Godwin Pumps of America, Inc. All rights reserved.