

GSP160, GSP300 Sub-Prime® Electric Submersible Dewatering Pumps

GSP160
GSP300

The line of Godwin Sub-Prime GSP electric submersible pumps is designed for large dewatering applications requiring high head or high volume. The GSP160 and GSP300 models are capable of maximum flow rates from 330 to 1,650 gpm (74.9 to 364.6 M³/hr.) and maximum discharge heads from 115 to 243 feet (35.1 to 74M). Like the small dewatering and trash handling models in the Sub-Prime line, these large dewatering submersible pumps are suited to tough construction, mining and industrial applications. They feature a slim-line design ideal for fitting into confined spaces and rugged construction for longer life, specifically a cast chromium steel impeller and heavy duty rubber coated adjustable wear parts. Other features include tandem mechanical seals for dry running and extra protection against leakage, and a dual voltage junction chamber for convenient changeover in the field.



Features

- Convenient top discharge
- Compact slim-line design
- Oversized power cable
- Dual voltage junction chamber
- High performance submersible motor
- Oversized, heavy duty ball bearings
- Tandem mechanical seals – Silicon Carbide on Silicon Carbide primary seal
- Cast Chromium Steel impeller and heavy duty rubber coated adjustable wearparts
- Lightweight aluminum and corrosion resistant stainless steel cooling jacket
- Dry running capabilities
- Optional manual and automatic control panels available

Specifications Three-Phase Models

	Model	
	GSP160	GSP300
<i>HP (kW)</i>	16 (11.9)	30 (22.4)
<i>Max. GPM (M³/hr.)</i>		
HV	1,200 (272.4)	1,650 (374.6)
HH	330 (74.9)	850 (193.0)
<i>Max. Head - Ft. (M)</i>		
HV	115' (35.1M)	150' (45.7M)
HH	243' (74M)	215' (65.5M)
<i>Discharge</i>	6" (150mm)	6" (150mm)
<i>Cable</i>	65' (20M)	65' (20M)
<i>RPM</i>	3500	3500
<i>Max. Temp.</i>	103°F (40°C)	103°F (40°C)
<i>PH Range</i>	5.0-8.0	5.0-8.0
<i>Voltage</i>	230/460, 575	230/460, 575
<i>Phase</i>	3	3
<i>Amps (230V/460V)</i>		
HV	41/20, 16	72/36, 29
HH	44/22, 18	78/39, 31
<i>Weight</i>	267 lbs. 121 kg.	355 lbs. 161 kg.
<i>Max. Solids</i>	.5" (13mm)	.5" (13mm)

HV = High Volume
HH = High Head



GSP160, GSP300 Sub-Prime® Performance Curves

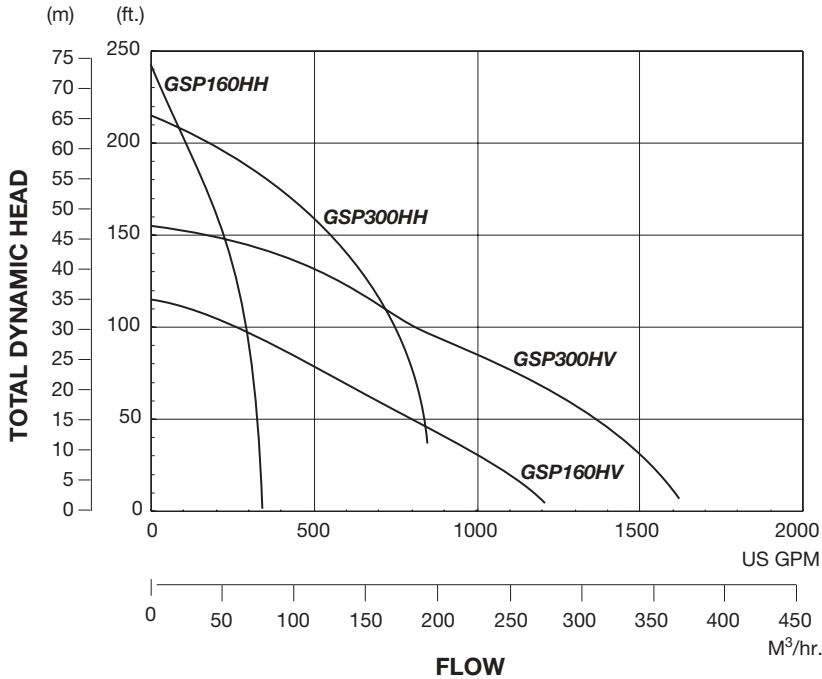

WARNING: Pumps are not designed for use in explosive atmosphere, flammable environments or for pumping volatile liquids.

Design & Construction

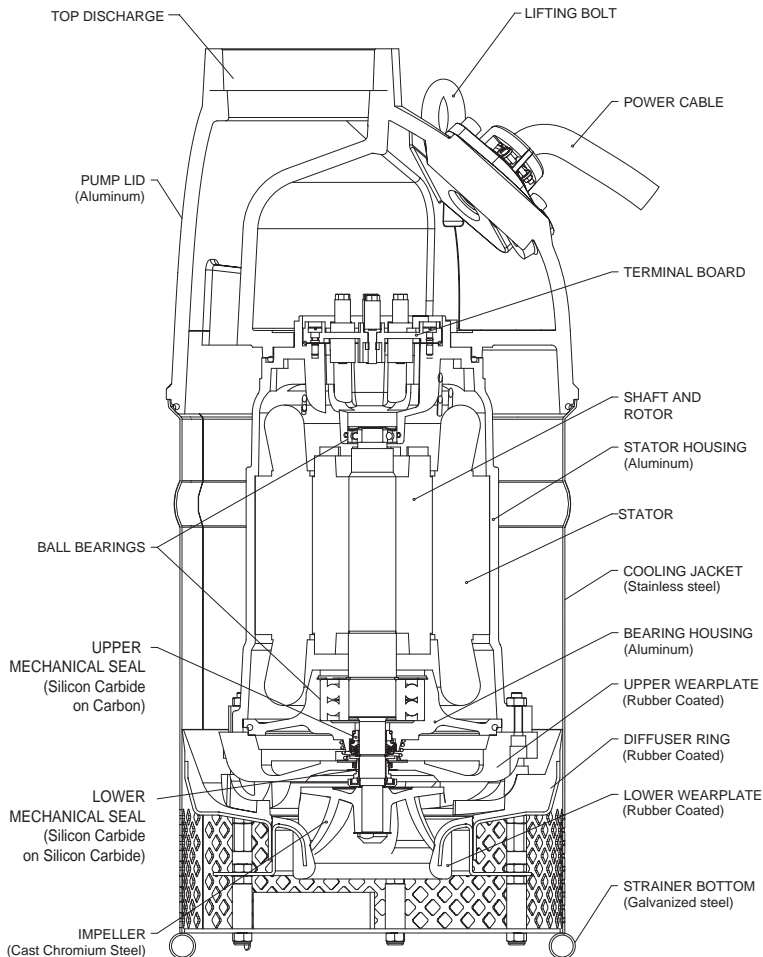

Dimensions

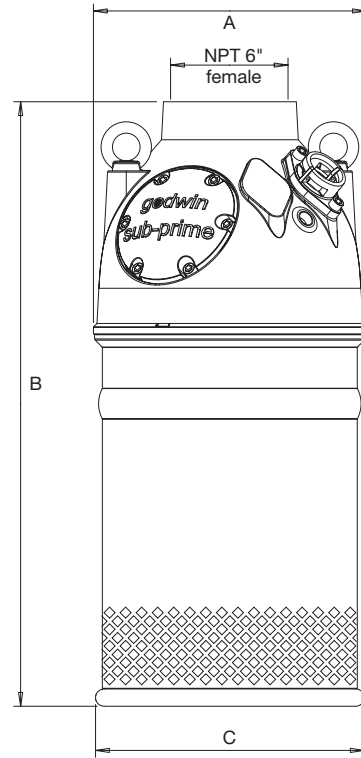

Model	A	B	C
GSP160	15.55" 395mm	34.45" 875mm	15.31" 389mm
GSP300	15.55" 395mm	39.15" 995mm	16.06" 408mm

godwin
pumps



One Floodgate Road, Bridgeport, NJ 08014, USA
(856) 467-3636 • Fax: (856) 467-4841

Quenington, Cirencester, Glos., GL7 5BX, UK
+44 (0)1285-750271 • Fax: +44 (0)1285-750352

E-mail: sales@godwinpumps.com

www.godwinpumps.com

BRANCH LOCATIONS:

Connecticut • Pennsylvania • New York • Ohio
Illinois • Maryland • Virginia • West Virginia
North Carolina • South Carolina • Georgia
Florida • Texas • Montana • California • Washington

Sub-Prime® is a registered trademark of Godwin Pumps of America, Inc.
Specifications and illustrations are subject to revision without notice.

© Copyright 2002-2005 Godwin Pumps of America, Inc. All rights reserved.

GPASL.087.505