

HL130M Dri-Prime® Pumps

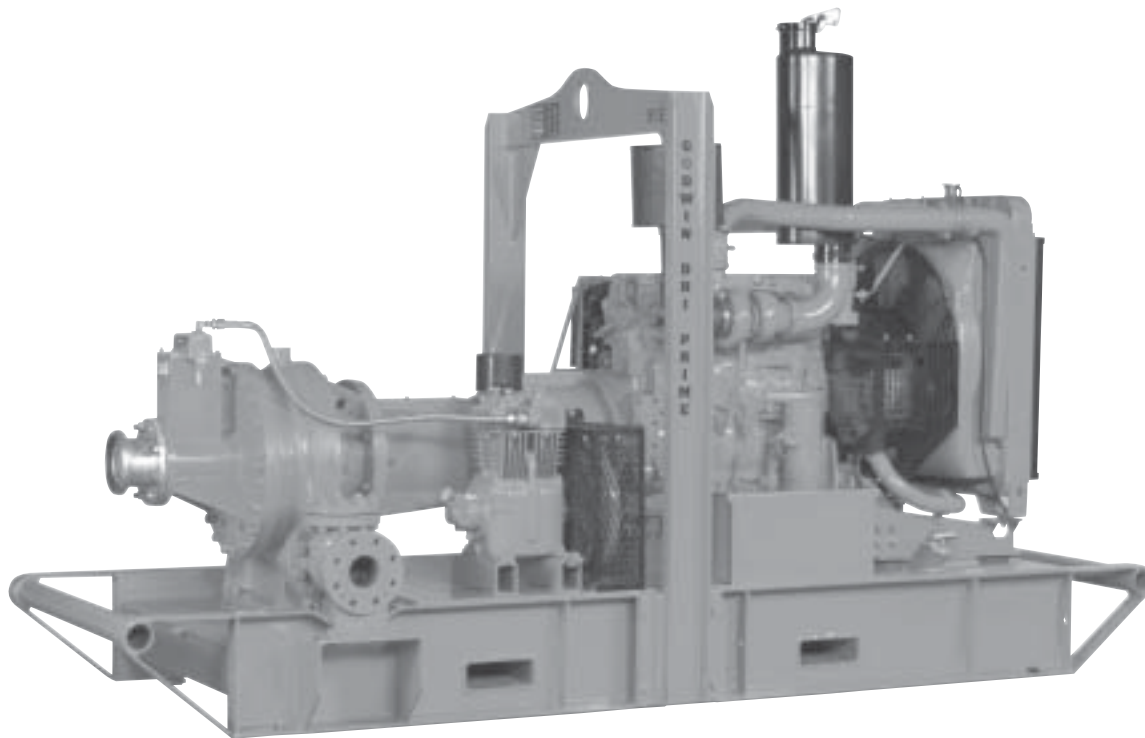

The Godwin Dri-Prime 6" x 4" (150mm x 100mm) HL130M is a heavy duty, fully automatic self-priming pump specifically offered for pumping under discharge pressure conditions or high discharge lift applications. The HL130M offers flowrates up to 1,300 gpm (82 l/sec.), total dynamic heads up to 650 feet (198M), and solids handling up to 1-3/8" (35mm) in diameter. Like all Godwin pumps, the HL130M includes the Dri-Prime air ejector priming system for fully automatic priming up to 28 feet (8.5M) of static suction lift.

Features

- Fully automatic priming from dry to 28 feet (8.5M) of suction lift. Maximum heads to 650 feet (198M). Maximum flows to 1,300 gpm (82 l/sec.).
- Handles liquids with solids up to 1-3/8" (35mm) in diameter.
- Continuously operated venturi air ejector priming system operated by an air compressor requiring no form of periodic adjustment or operator intervention.
- Double, high pressure mechanical seal with high abrasion resistant silicon carbide interfaces. Oil bath immersion for dry running.
- Mounted to a structural steel skid with integral 250 gal. (946 liter) fuel tank and lifting bail.
- Standard engine — Caterpillar C-9 diesel. Other engines available. Electric drive version also available.

HL130M Performance Curve

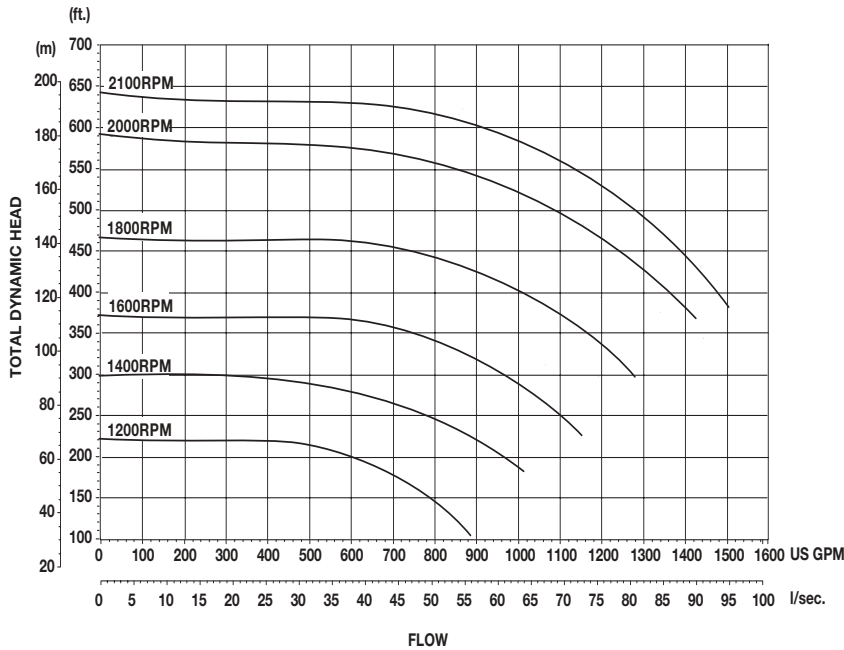

HL130M Performance Table

Diesel Set — Caterpillar C-9, 300 hp (205 kw) @ 2200 rpm
Impeller Diameter: 20-1/4" (514 mm)

Total Suction	Total Delivery Head – Feet				
	361	394	459	525	558
Head – Feet	Output – GPM				
10	1404	1334	1201	999	792
15	1391	1320	1188	973	761
20	1382	1307	1171	942	673
25	1373	1298	1157	911	616

Performance data listed in table and curves based on water test at sea level and 68° F (20° C). Maximum flows may require larger diameter pipes.

Dimensions

HL130M — Caterpillar C-9, Skid Base
Weight: 11,500 lbs. (5,227 kg.)

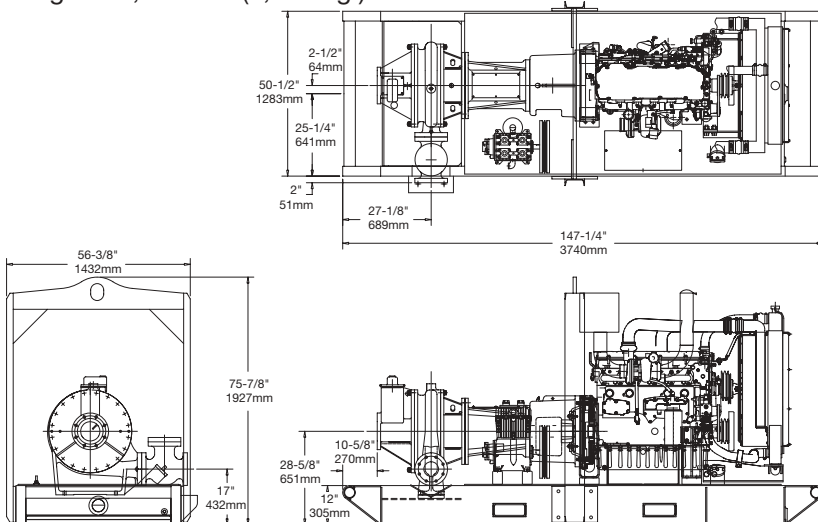

Specifications

- Maximum Operating Speed:** 2100 rpm
- Maximum Operating Temperature:** 194° F (90° C)
- Maximum Working Pressure:** 285 psi (19.6 BAR)
- Maximum Suction Pressure:** 90 psi (6.2 BAR)
- Maximum Casing Pressure:** 425 psi (29.3 BAR)
- Fuel Tank Capacity:** 250 gal. (946 liters)
- Fuel Consumption:** 13.5 gph (51.1 lph)
- Pipe Connections:** Suction: 6" (150mm) ASA 150
Discharge: 4" (100mm) ASA 300
- Solids Handling:** 1-3/8" (35mm) dia.

Materials

- Pump Casing and Bearing Casing:** Close grained cast iron
- Impeller:** Cast chromium steel
- Wearplates:** Cast chromium iron
- Mechanical Seal:** Solid silicon carbide faced, oil bath lubricated



One Floodgate Road, Bridgeport, NJ 08014, USA
 (856) 467-3636 • Fax: (856) 467-4841
 Quenington, Cirencester, Glos., GL7 5BX, UK
 +44 (0)1285 750271 • Fax: +44 (0)1285 750352

E-mail: sales@godwinpumps.com
 www.godwinpumps.com

- BRANCH LOCATIONS:**
 Connecticut • Pennsylvania • New York • Ohio
 Illinois • Maryland • Virginia • West Virginia
 Georgia • South Carolina • North Carolina
 Florida • Texas • Montana • California • Washington

Dri-Prime® and the color orange for pumps are registered trademarks of Godwin Pumps of America, Inc.
 Specifications and illustrations are subject to revision without notice.
 © Copyright 2002-2003 Godwin Pumps of America, Inc.
 GPASL.104.904