

# HL225M Dri-Prime® Pumps

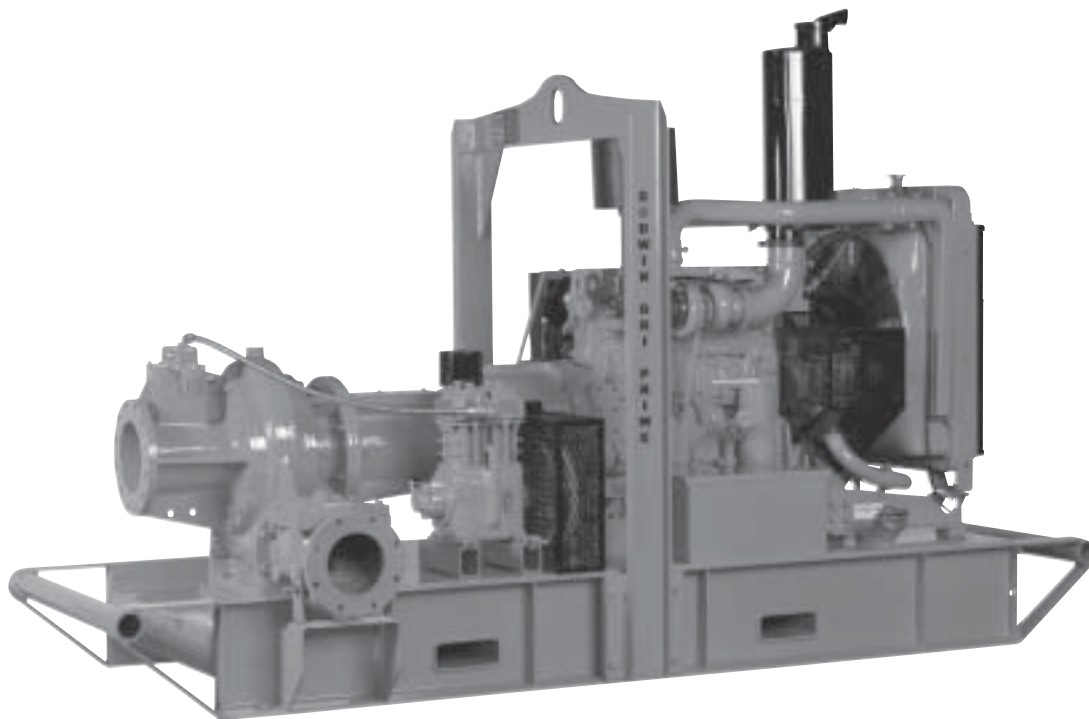

The Godwin Dri-Prime 10" x 8" (250mm x 200mm) HL225M is a heavy duty, fully automatic self-priming pump specifically offered for pumping under discharge pressure conditions or high discharge lift applications. The HL225M offers flowrates up to 3,600 gpm (227 l/sec.), total dynamic heads up to 380 feet (116M), and solids handling up to 2-9/16" (65mm) in diameter. Like all Godwin pumps, the HL225M includes the Dri-Prime air ejector priming system for fully automatic priming up to 28 feet (8.5M) of static suction lift.

## Features

- Fully automatic priming from dry to 28 feet (8.5M) of suction lift. Maximum heads to 380 feet (116M). Maximum flows to 3,600 gpm (227 l/sec.).
- Handles liquids with solids up to 2-9/16" (65mm) in diameter.
- Continuously operated venturi air ejector priming system operated by an air compressor requiring no form of periodic adjustment or operator intervention.
- Dual, high pressure, dry running solid silicon carbide inboard and carbon/stainless outboard mechanical seal with self-contained oil bath cooling.
- Mounted to a structural steel skid with integral 250 gal. (946 liter) fuel tank and lifting bail.
- Standard engine — Caterpillar C-9 diesel. Other engines available. Electric drive version also available.

# HL225M Performance Curve

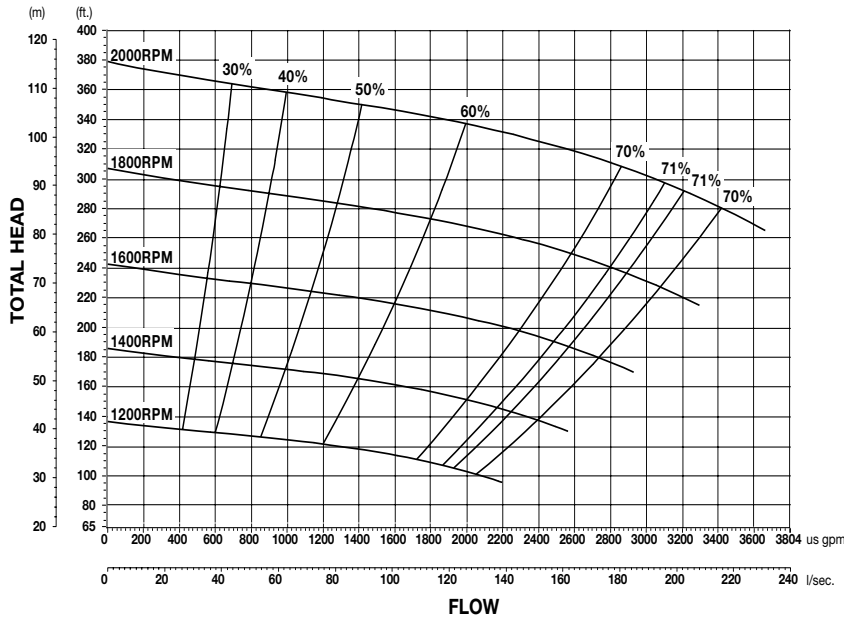

## HL225M Performance Table

**Diesel Set** — Caterpillar C-9, 300 hp (205 kw) @ 1800 rpm  
**Impeller Diameter:** 17-5/16" (440 mm)

Total Suction Head – Feet	Total Delivery Head – Feet			
	150	200	250	300
10	3600	3550	3450	3020
15	3540	3520	3440	2800
20	3000	2950	2920	2620
25	2180	1980	1900	1850

Performance data listed in table and curves based on water test at sea level and 68° F (20° C). Maximum flows may require larger diameter pipes.

## Dimensions

HL225M — Caterpillar C-9, Skid Base  
 Weight: 10,500 lbs. (4,273 kg.)

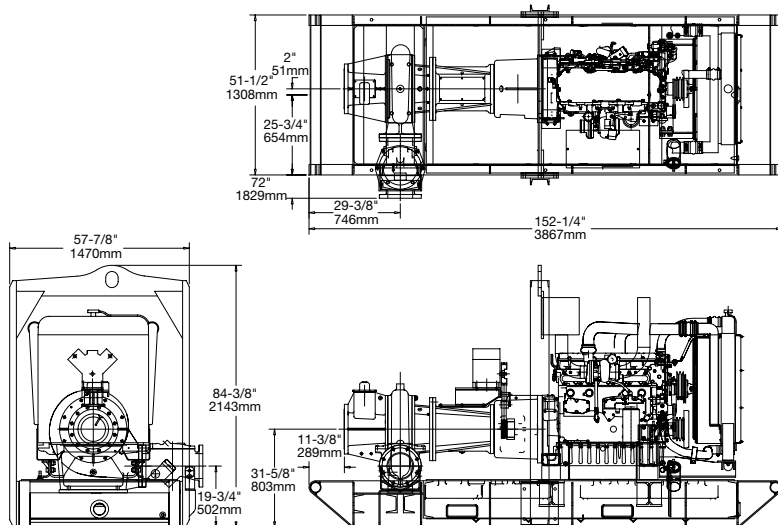

## Specifications

- Maximum Operating Speed:** 2000 rpm
- Maximum Operating Temperature:** 194° F (90° C)
- Maximum Working Pressure:** 185 psi (13 BAR)
- Maximum Suction Pressure:** 90 psi (6.2 BAR)
- Maximum Casing Pressure:** 280 psi (19.5 BAR)
- Fuel Tank Capacity:** 250 gal. (946 liters)
- Fuel Consumption:** 13.6 gph (51.5 lph)
- Pipe Connections:**
  - Suction: 10" (250mm) ASA 150
  - Discharge: 8" (200mm) ASA 300
- Solids Handling:** 2-9/16" (65mm) dia.

## Materials

- Pump Casing, Bearing Casing and Non Return Valve:** Close grained cast iron
- Impeller:** Cast chromium steel hardened to minimum Brinell 293 HB
- Wearplates:** Nickel-Chrome cast iron, replaceable
- Mechanical Seal:** Solid silicon carbide faced, dry running, dual high pressure mechanical seal cooled by oil bath



One Floodgate Road, Bridgeport, NJ 08014, USA  
 (856) 467-3636 • Fax: (856) 467-4841  
 Quenington, Cirencester, Glos., GL7 5BX, UK  
 +44 (0)1285 750271 • Fax: +44 (0)1285 750352

E-mail: sales@godwinpumps.com  
 www.godwinpumps.com

### BRANCH LOCATIONS:

- Connecticut • Pennsylvania • New York • Ohio
- Illinois • Maryland • Virginia • West Virginia
- Georgia • South Carolina • North Carolina
- Florida • Texas • Montana • California • Washington

Dri-Prime® and the color orange for pumps are registered trademarks of Godwin Pumps of America, Inc. Specifications and illustrations are subject to revision without notice. © Copyright 2004 Godwin Pumps of America, Inc.